

Embroidery preparations

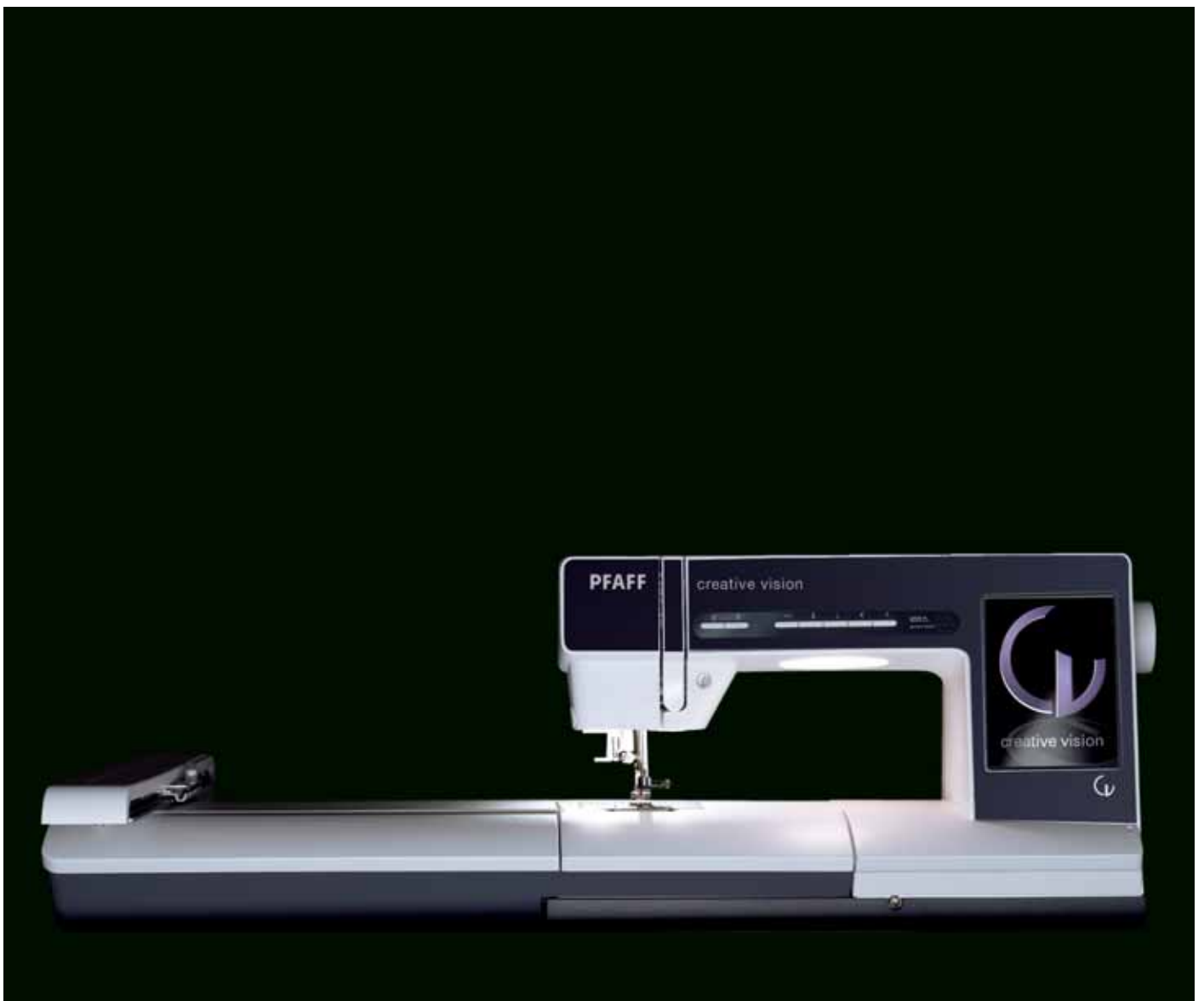

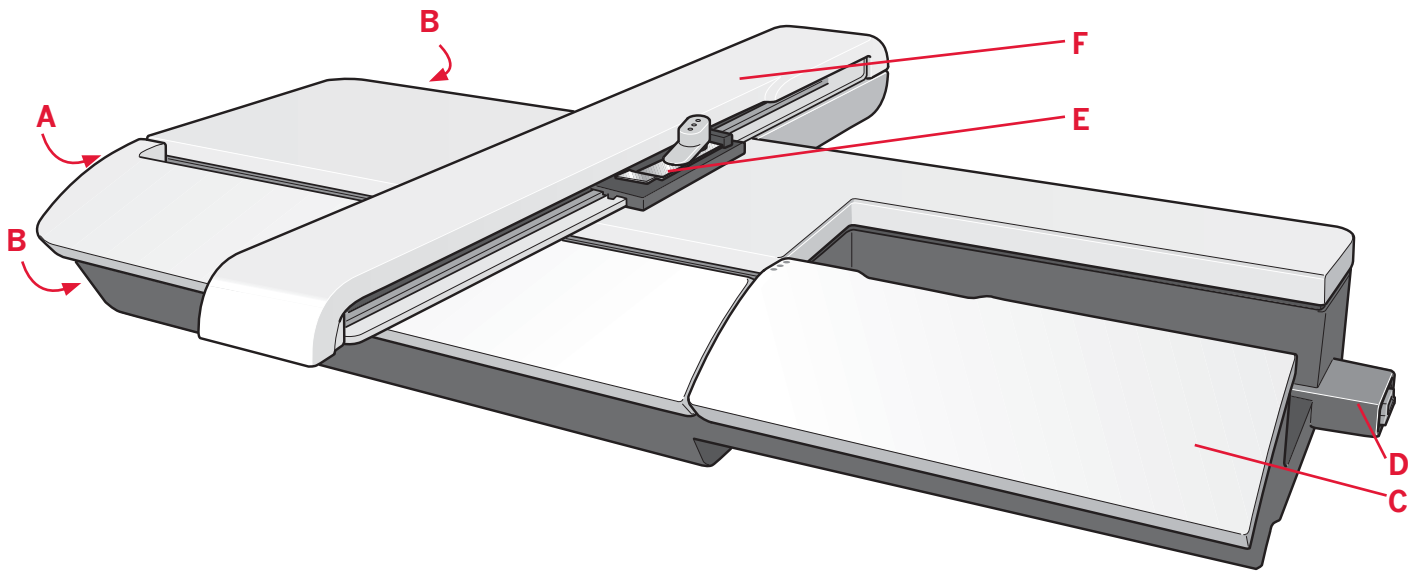

Embroidery unit overview

(type BE15)

- A Embroidery unit release button
- B Level adjusting feet
- C Embroidery unit accessory tray
- D Embroidery unit socket
- E Embroidery hoop connection assembly
- F Embroidery arm

Note: A smaller embroidery unit, 260x200mm, is available to purchase at your local authorized PFAFF® dealer.

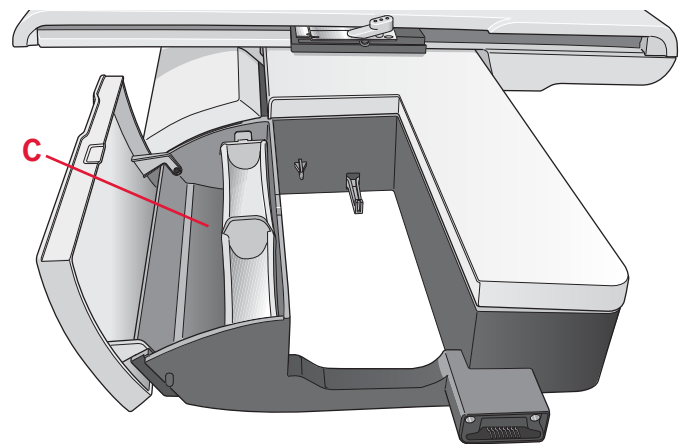

Embroidery unit accessory tray

Use the tray in the embroidery unit to store accessories used for embroidering.

Built-in designs

Over 250 designs are included in the memory in your machine.

Embroidery hoop overview

- G Embroidery hoop connector
- H Outer hoop
- I Inner hoop
- J Quick release
- K Retaining screw
- L Ribs for fitting the clips
- M Center marks

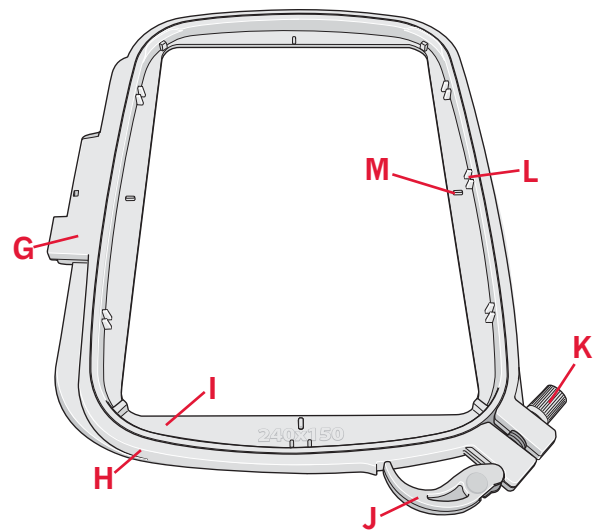

creative vision™ Embroidery collection

Page through the creative vision™ Embroidery collection for designs and fonts.

The design number, stitch count (number of stitches in the design) and the design size are displayed next to each design. The suggested thread colors for each color number are shown.

Connect the embroidery unit

There is a covered socket behind the free-arm, see picture. The cover will open automatically when connecting the embroidery unit.

1. Slide the accessory tray off.
2. Slide the embroidery unit onto the free arm of the machine until it plugs firmly into the socket. If needed, use the level adjusting feet so that the machine and embroidery unit are even. If the machine is turned off, turn it on.
3. A pop-up tells you to clear the embroidery area and remove the hoop for positioning. Touch OK. The machine will calibrate and the embroidery arm will move to the ready position. This calibration will set your embroidery functions each time you slide on the embroidery unit.

Make sure not to calibrate the machine with the embroidery hoop attached as this can damage the needle, presser foot, hoop and/or the embroidery unit. Be sure to clear all materials from around the machine before calibrating so that the embroidery arm does not bump into anything while calibrating.

Remove the embroidery unit

1. To store the embroidery unit in the embroidery case, move the embroidery arm to park position by selecting park position on the screen in either embroidery edit or embroidery stitch-out.
2. Press the button at the left, underneath the embroidery unit (A) and slide the unit to the left to remove it.
3. The cover of the socket closes automatically.
4. Store the embroidery unit in the original packing material, place in the soft carrying bag.

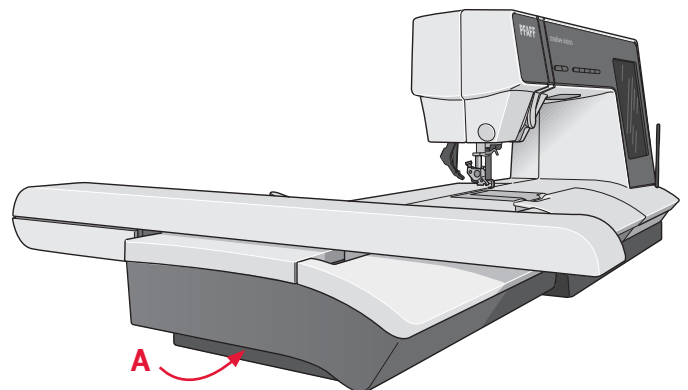
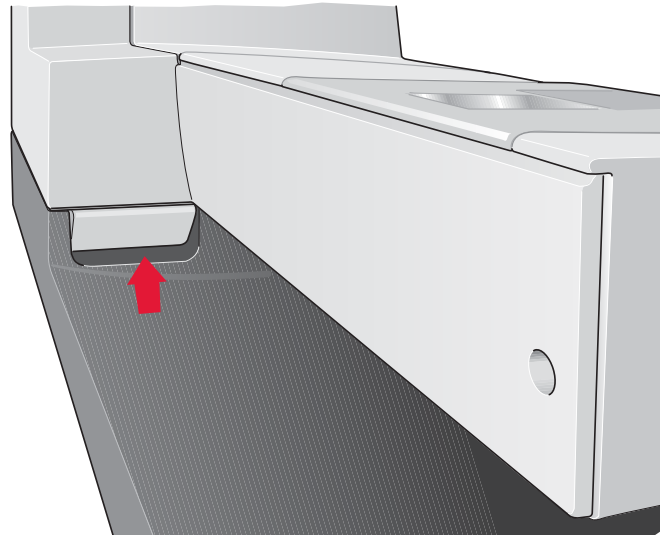

To hoop the fabric

For the best embroidery results, place a layer of stabilizer beneath the fabric. When hooping stabilizer and fabric make sure that they are smooth and securely hooped.

1. Open the quick release (A) on the outer hoop. Remove the inner hoop. Place the outer hoop on a firm flat surface with the screw on the lower right. There is a small arrow in the center of the lower edge of the hoop which will line up with a small arrow on the inner hoop.
2. Place stabilizer and the fabric, with the right sides facing up, on top of the outer hoop. Place the inner hoop on top of the fabric with the small arrow at the bottom edge.
3. Push the inner hoop firmly into the outer hoop.
4. Close the quick release. Adjust the pressure of the outer hoop by turning the retaining screw (B). The fabric should be taut in the hoop for the best results.

Note: When embroidering additional designs on the same fabric, open the quick release, move the hoop to the new position on the fabric and close the quick release. When changing type of fabric, you might need to adjust the pressure using the retaining screw. Do not force the quick release.

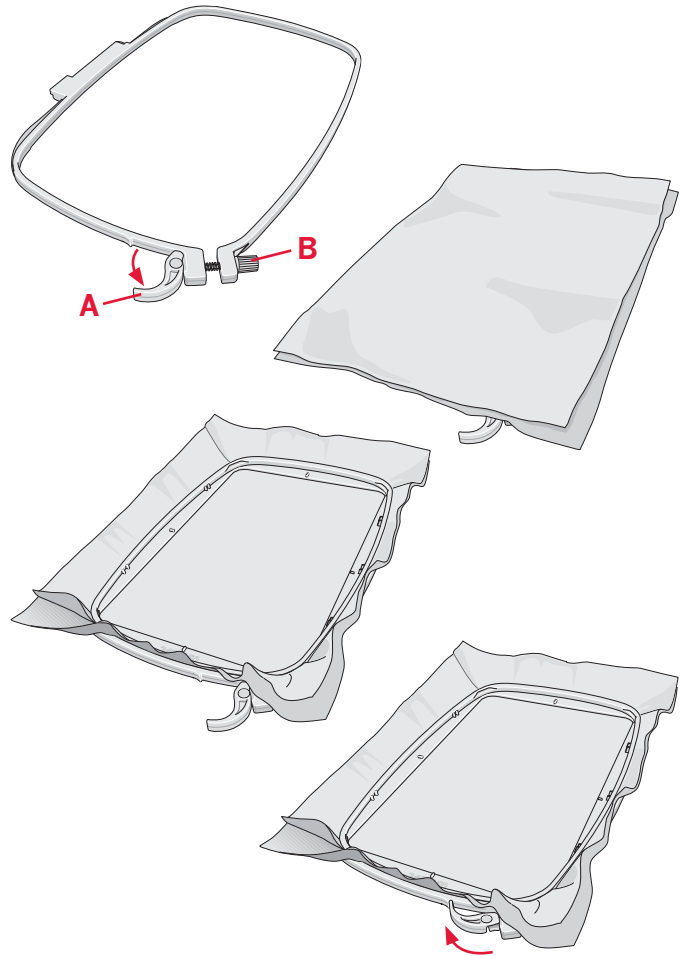

Slide on the hoop

Make sure that the accessory tray on the embroidery unit is closed. Slide the hoop onto the embroidery unit from front to back until it clicks into place.

The marked center point on the design should match the starting point of the needle. If minor adjustments are needed use the icons on the screen (See chapter 8).

To remove the hoop from the embroidery arm, press the grey button on the hoop connection assembly and slide the hoop towards you.

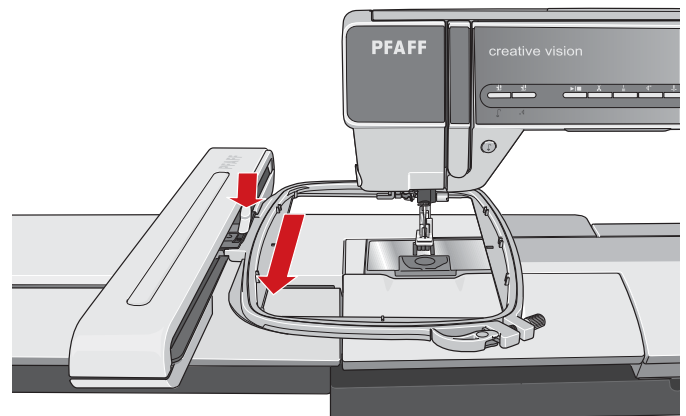
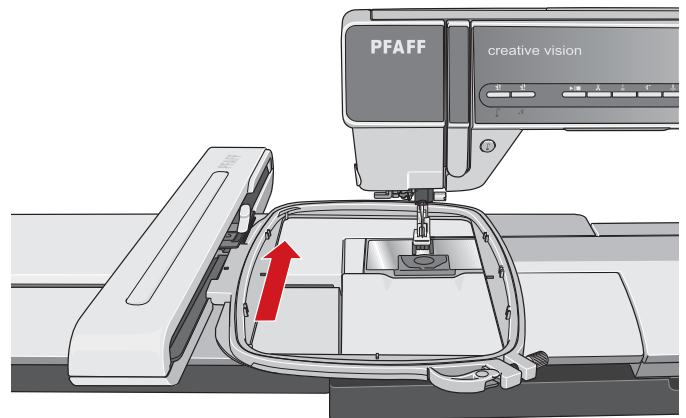

Getting started embroidering

1. After attaching the embroidery unit and embroidery foot, insert a bobbin with lightweight bobbin thread.
Note: Make sure that the IDT is disengaged.
2. Hoop a piece of fabric and slide on the hoop.
3. Open selection menu (A) to select a design.
Touch it once to load to embroidery edit.

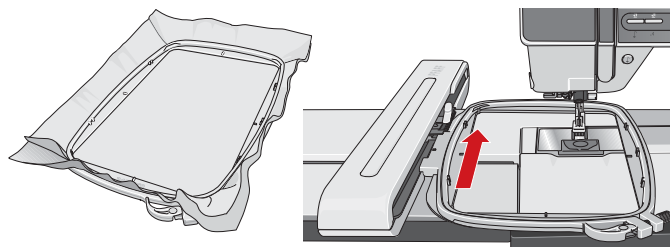

4. The machine automatically switches to embroidery edit. The design is placed in the center of the hoop.



5. Switch from embroidery edit to embroidery stitch-out by touching the embroidery toggle icon (B) on the task bar.
6. Thread the machine with the first color in the color list (C).



7. Clear sufficient space to accommodate movement of the embroidery arm and the hoop. Hold the needle thread and touch the start/stop button (D) or the foot control. The machine starts embroidering.

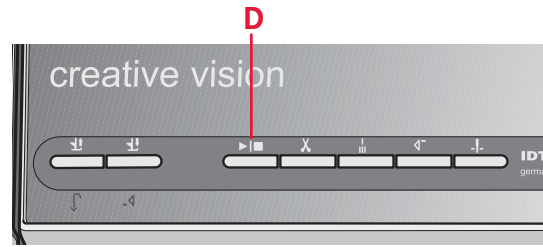

8. After stitching a few stitches, the machine stops and a pop-up appears on the screen asking you to cut the thread end. Cut the thread and press start/stop to continue embroidering.



9. When the first color is completed, your machine stops. A pop-up appears asking you to change color. Re-thread with the next color and continue embroidering by pressing start/stop. Each color segment is tied off at the end and the needle thread is cut.

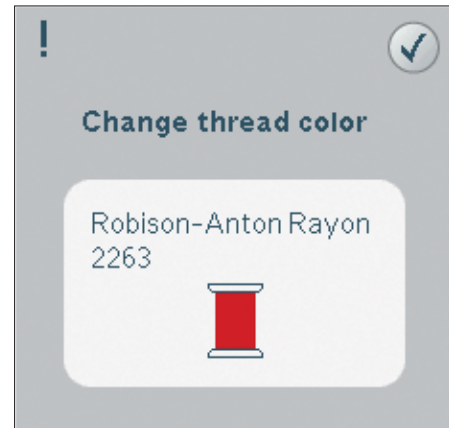

10. When the embroidery is completed, your machine cuts the needle and bobbin thread and stops. The needle and presser foot raise automatically for easy removal of the hoop. A pop-up informs you that your embroidery is finished. Touch OK to clear your design from the screen.

